



TECHNICAL REPORT

TR-159

Management Framework for xDSL Bonding

Issue: 1
Issue Date: December 2008

Notice

The Broadband Forum is a non-profit corporation organized to create guidelines for broadband network system development and deployment. This Broadband Forum Technical Report has been approved by members of the Forum. This Broadband Forum Technical Report is not binding on the Broadband Forum, any of its members, or any developer or service provider. This Broadband Forum Technical Report is subject to change, but only with approval of members of the Forum. This Technical Report is copyrighted by the Broadband Forum, and all rights are reserved. Portions of this Technical Report may be copyrighted by Broadband Forum members.

This Broadband Forum Technical Report is provided AS IS, WITH ALL FAULTS. ANY PERSON HOLDING A COPYRIGHT IN THIS BROADBAND FORUM TECHNICAL REPORT, OR ANY PORTION THEREOF, DISCLAIMS TO THE FULLEST EXTENT PERMITTED BY LAW ANY REPRESENTATION OR WARRANTY, EXPRESS OR IMPLIED, INCLUDING, BUT NOT LIMITED TO, ANY WARRANTY:

- (A) OF ACCURACY, COMPLETENESS, MERCHANTABILITY, FITNESS FOR A PARTICULAR PURPOSE, NON-INFRINGEMENT, OR TITLE;
- (B) THAT THE CONTENTS OF THIS BROADBAND FORUM TECHNICAL REPORT ARE SUITABLE FOR ANY PURPOSE, EVEN IF THAT PURPOSE IS KNOWN TO THE COPYRIGHT HOLDER;
- (C) THAT THE IMPLEMENTATION OF THE CONTENTS OF THE DOCUMENTATION WILL NOT INFRINGE ANY THIRD PARTY PATENTS, COPYRIGHTS, TRADEMARKS OR OTHER RIGHTS.

By using this Broadband Forum Technical Report, users acknowledge that implementation may require licenses to patents. The Broadband Forum encourages but does not require its members to identify such patents. For a list of declarations made by Broadband Forum member companies, please see <http://www.broadband-forum.org>. No assurance is given that licenses to patents necessary to implement this Technical Report will be available for license at all or on reasonable and non-discriminatory terms.

ANY PERSON HOLDING A COPYRIGHT IN THIS BROADBAND FORUM TECHNICAL REPORT, OR ANY PORTION THEREOF, DISCLAIMS TO THE FULLEST EXTENT PERMITTED BY LAW (A) ANY LIABILITY (INCLUDING DIRECT, INDIRECT, SPECIAL, OR CONSEQUENTIAL DAMAGES UNDER ANY LEGAL THEORY) ARISING FROM OR RELATED TO THE USE OF OR RELIANCE UPON THIS TECHNICAL REPORT; AND (B) ANY OBLIGATION TO UPDATE OR CORRECT THIS TECHNICAL REPORT.

Broadband Forum Technical Reports may be copied, downloaded, stored on a server or otherwise re-distributed in their entirety only, and may not be modified without the advance written permission of the Broadband Forum.

The text of this notice must be included in all copies of this Broadband Forum Technical Report.

Issue History

Issue Number	Issue Date	Issue Editor	Changes
1	December 2008	Edward Beili M. Morgenstern	Original

Technical comments or questions about this Broadband Forum Technical Report should be directed to:

Editors:

Edward Beili	Actelis Networks	edward.beili@actelis.com
Moti Morgenstern	ECI Telecom	Moti.Morgenstern@ecitele.com

O&NM WG Chair Peter Adams BT

Table of Contents

1	PURPOSE AND SCOPE	7
1.1	PURPOSE	7
1.2	SCOPE	7
2	REFERENCES AND TERMINOLOGY	8
2.1	CONVENTIONS	8
2.2	REFERENCES	8
2.3	DEFINITIONS	9
2.4	ABBREVIATIONS	10
3	TECHNICAL REPORT IMPACT	12
3.1	ENERGY EFFICIENCY	12
3.2	IPv6.....	12
3.3	SECURITY.....	12
4	XDSL MULTI-PAIR BONDING OVERVIEW	13
4.1	LAYERING MODEL	13
4.2	PERFORMANCE MONITORING.....	14
4.2.1	<i>Errored Second (ES)</i>	14
4.2.2	<i>Severely Errored Second (SES)</i>	14
4.2.3	<i>Unavailable Second (UAS)</i>	15
4.2.4	<i>Inhibiting rules</i>	15
4.2.5	<i>Performance data storage</i>	15
4.2.6	<i>Performance data thresholds</i>	15
5	MANAGEMENT FRAMEWORK STRUCTURE	16
5.1	MANAGEMENT MODEL	16
5.2	CONTAINMENT	16
5.3	MANAGED OBJECTS	17
5.4	CAPABILITIES.....	18
5.5	ELEMENT DEFINITIONS FOR THE MANAGED OBJECTS	23
5.5.1	<i>oBondingGroup</i>	24
5.5.2	<i>oBondATM</i>	39
5.5.3	<i>oBondEth</i>	41
5.5.4	<i>oBondTDIM</i>	44
5.5.5	<i>oTDIMService</i>	48
5.5.6	<i>oLine</i>	51
5.5.7	<i>oChannel</i>	54

List of Figures

Figure 4-1: Layering diagram for xDSL Bonded interfaces 14
Figure 5-1: xDSL Bonding – Entity Relationship diagram 17

List of Tables

Table 5-1: xDSL Multi-pair Bonding Management Capabilities 19

Summary

This Broadband Forum Technical Report provides a management framework for the xDSL bonding specified in ITU-T recommendations G.998.1 (ATM-based multi-pair bonding), G.998.2 (Ethernet-based multi-pair bonding) and G.998.3 (Multi-pair bonding using time-division inverse multiplexing). xDSL bonding enables a Network Provider to provide xDSL service over longer loops or to provide higher bandwidths over existing loops. The ITU-T Recommendations do not specify the management of bonding. This Technical Report defines the required managed objects in a protocol independent manner, which means it does not refer to any particular management protocol between the Element Management System (EMS) and the Network Element (NE). The management framework facilitates the deployment of bonded xDSL by enabling bonding to be configured and monitored in a standardised way.

1 Purpose and Scope

1.1 Purpose

The purpose of this Broadband Forum Technical Report is to define the management framework for xDSL bonding technology per ITU-T recommendations G.998.1 (ATM-based multi-pair bonding), G.998.2 (Ethernet-based multi-pair bonding) and G.998.3 (Multi-pair bonding using time-division inverse multiplexing). This Technical Report defines the required managed objects and hierarchical relationships between them. The management framework is protocol independent, which means it does not refer to any particular management protocol between the Element Management System (EMS) and the Network Element (NE).

1.2 Scope

This Broadband Forum Technical Report provides a management model for xDSL multi-pair bonding based on ATM, Ethernet or TDIM.

2 References and Terminology

2.1 Conventions

In this Technical Report, several words are used to signify the requirements of the specification. These words are often capitalized. More information can be found in RFC 2119 [8].

MUST	This word, or the terms “REQUIRED” or “SHALL”, mean that the definition is an absolute requirement of the specification.
MUST NOT	This phrase, or the phrase “SHALL NOT”, mean that the definition is an absolute prohibition of the specification.
SHOULD	This word, or the adjective “RECOMMENDED”, means that there may exist valid reasons in particular circumstances to ignore this item, but the full implications must be understood and carefully weighed before choosing a different course.
SHOULD NOT	This phrase, or the phrase “NOT RECOMMENDED” means that there may exist valid reasons in particular circumstances when the particular behavior is acceptable or even useful, but the full implications should be understood and the case carefully weighed before implementing any behavior described with this label.
MAY	This word, or the adjective “OPTIONAL”, means that this item is one of an allowed set of alternatives. An implementation that does not include this option MUST be prepared to inter-operate with another implementation that does include the option.

2.2 References

The following references constitute provisions of this Technical Report. At the time of publication, the editions indicated were valid. All references are subject to revision; users of this Technical Report are therefore encouraged to investigate the possibility of applying the most recent edition of the references listed below.

A list of currently valid Broadband Forum Technical Reports is published at www.broadband-forum.org

- [1] ITU-T G.998.1 (January 2005), *ATM-based multi-pair bonding*
- [2] ITU-T G.998.2 (January 2005), *Ethernet-based multi-pair bonding*
- [3] ITU-T G.998.3 (January 2005), *Multi-pair bonding using time-division inverse multiplexing*
- [4] ITU-T G.998.2 Amendment 2 (December 2007), *Ethernet-based multi-pair bonding Amendment 2.*
- [5] IETF RFC 2863 (June 2000), *The Interfaces Group MIB*

- [6] IETF RFC 4319 (December 2005), *Definitions of Managed Objects for HDSL2 and SHDSL Lines*
- [7] IETF RFC 3728 (February 2004), *Definitions of Managed Objects for VDSL*
- [8] IETF RFC 2119 (March 1997), *Key words for use in RFCs to Indicate Requirement Levels*
- [9] IETF RFC 2495 (January 1999), *Definitions of Managed Objects for the DS1, E1, DS2 and E2 Interface Types*
- [10] ANSI T1.231-1997 (October 1997), *Digital Hierarchy – Layer 1 In-Service Digital Transmission Performance Monitoring*
- [11] IEEE Std. 802.3-2005 (December 2005), *Local and metropolitan area networks - Specific requirements - Part 3: Carrier sense multiple access with collision detection (CSMA/CD) access method and physical layer specifications*
- [12] ISO/IEC 10165-4: 1992, *Information technology—Open Systems Interconnection—Management information services—Structure of management information—Part 4: Guidelines for the definition of managed objects.*

2.3 Definitions

The following definitions apply for the purposes of this Technical Report:

Asynchronous Transfer Mode (ATM)	A connection-oriented high-speed communications protocol in which data is divided into 48 byte “cells” that can be individually switched and routed. Each cell is pre-appended with a 5 byte “header” containing an identifier of the connection of which the data is a part, along with quality of service parameters associated with the connection.
Bearer channel	A data stream at a specified data rate between two TPS-TC entities (one in each BTU) that is transported transparently over a single latency path by the PMS-TC and PMD sub-layers
Downstream	Information flow whose direction is from a Service Provider System (a.k.a. Central Office [CO] side) to an End-Service Consumer System (a.k.a. Remote Terminal [RT] side or Customer Premises Equipment [CPE]).
Layer/Sub-layer	A collection of objects of the same hierarchical rank.
Performance Monitoring	The process of continuous collection, analysis, and reporting of performance data associated with a transmission entity (e.g. a bonded port).
Upstream	Information flow whose direction is from an End-Service Consumer System (RT/CPE) to a Service Provider System (CO).

2.4 Abbreviations

The following abbreviations apply for the purposes of this Technical Report:

ATM	Asynchronous transfer mode
ATM-TC	Asynchronous transfer mode - transmission convergence (sub-layer)
BACP	Bonding Aggregation Control Protocol
BCE	Bonding Channel Entity
BTU	Bonding Terminating Unit
BTU-C	Bonding Terminating Unit, CO side
BTU-R	Bonding Terminating Unit, RT (or CPE) side
CPE	Customer Premises Equipment
CRC	Cyclic redundancy code
DSLAM	Digital subscriber line access multiplexer
EMS	Element management system
ES	Errored Second
FEC	Forward error correction
GBS	Generic Bonded Sub-layer
GBS-C	Generic Bonded Sub-layer, CO side
GBS-R	Generic Bonded Sub-layer, RT (or CPE) side
G.hs	xDSL Handshake
IMA	Inverse multiplexing for ATM
MBS	Multiple Bonding Schemes
NE	Network element
PMD	Physical media-dependent (sub-layer)
PME	Physical Medium Entity
PMS-TC	Physical media-specific - transmission convergence (sub-layer)
PTM-TC	Packet transfer mode - transmission convergence (sub-layer)
RO	Read-only
RT	Remote Terminal
RW	Read-write
SES	Severely Errored Second
STM	Synchronous transfer mode
TDIM	Time-division inverse multiplexing
TDM	Time-division multiplexing
TPS-TC	Transport protocol specific - transmission convergence (sub-layer)
UAS	Unavailable Second

xDSL a collective term referring to any of the various types of DSL technologies

3 Technical Report Impact

3.1 Energy Efficiency

TR-159 has no impact on energy efficiency.

3.2 IPv6

TR-159 has no impact on IPv6 support and compatibility.

3.3 Security

There are no relevant security issues relating to TR-159.

4 xDSL Multi-pair Bonding Overview

The xDSL Multi-Pair Bonding, specified in the three ITU-T recommendations below, allows a service provider to provide high bandwidth services to business and residential customers over multiple xDSL lines, with greater speed and resiliency, than the service over a single xDSL line, bridging the gap between xDSL and fiber-based transport.

There are three xDSL Multi-Pair Bonding schemes, also known under collective name G.998.x:

- The ATM-Based Multi-Pair Bonding, specified in ITU-T G.998.1 recommendation [1], which defines a method for bonding (or aggregating) of multiple xDSL lines (or individual bearer channels in multiple xDSL lines) into a single bi-directional logical link carrying an ATM stream. This specification can be viewed as an evolution of the old IMA technology, applied to xDSL with variable rates on each line/bearer channel.
- The Ethernet-Based Multi-Pair Bonding, specified in ITU-T G.998.2 recommendation [2], which defines a method for bonding (or aggregating) of multiple xDSL lines (or individual bearer channels in multiple xDSL lines) into a single bi-directional logical link carrying an Ethernet stream. This specification can be viewed as IEEE 802.3-2005 [11] Clause 61 PME Aggregation Function (PAF), generalized to work over any xDSL technology.
- The Multi-pair bonding using time-division inverse multiplexing (TDIM), specified in ITU-T G.998.3 recommendation [3], which defines a method for bonding (or aggregating) of multiple xDSL lines into a single bi-directional logical link carrying a mix of various traffic streams (e.g. Ethernet, ATM, TDM).

All schemes allow bonding of up to 32 individual sub-layers with variable rates, providing common functionality for the configuration, initialization, operation and monitoring of the bonded link.

4.1 Layering Model

Architecturally all three bonding schemes define a new “bonded” TPS-TC sub-layer, stacked above multiple ATM-TC, Ethernet/PTM-TC or STM-TC (clear channel) sub-layers for the ATM, Ethernet or TDIM bonding respectively. Each underlying TPS-TC sub-layer represents a protocol specific γ -interface to an xDSL line or an individual bearer channel of an xDSL line. Bonding of multiple bearer channels in the same xDSL line is not allowed.

For the purpose of brevity we will refer to the bonded interface as Generic Bonded Sub-layer (GBS) and to the channel sub-layer as Bonding Channel Entity (BCE).

A generic G.998.x device can have a number of GBS ports, each connected to a particular upper layer (e.g. Media Access Control (MAC) interface for G.998.2 scheme), while simultaneously cross-connected to a number of underlying BCEs, with a single GBS per BCE relationship.

The following figure shows the layering diagram for the bonded xDSL interfaces:

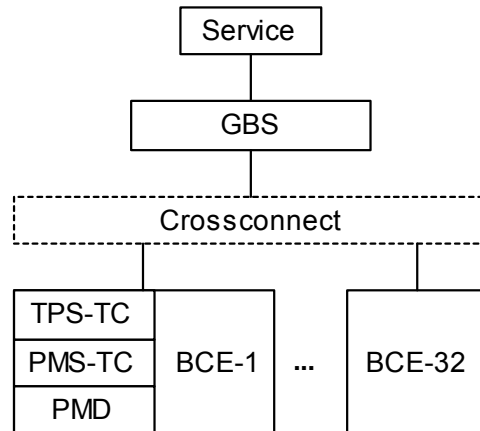

Figure 4-1: Layering diagram for xDSL Bonded interfaces

4.2 Performance Monitoring

None of the ITU-T G.998 recommendations addressed the issue of historical performance monitoring, beyond definition of accumulative error counters. This Technical Report defines an OPTIONAL performance monitoring based on continuous counters, 15-minutes and 24-hours (1-day) history counters in the following sections.

See TI.231 [10] for the definitions of performance monitoring terminology, parameters and primitives.

4.2.1 Errored Second (ES)

An Errored Second for a G.998.x interface is defined as a count of 1-second intervals during which one or more GBS errors are declared. The errors are specific for each bonding scheme, e.g.

- lost cells for the ATM bonding;
- lost or discarded (due to an error or a buffer overflow) fragments for the Ethernet bonding;
- CRC4, CRC6 or CRC8 errors for the TDM bonding.

This parameter is subject to inhibiting – see 4.2.4.

4.2.2 Severely Errored Second (SES)

A Severely Errored Second for a G.998.x interface is defined as a count of 1-second intervals during which GBS errors cause at least 1% traffic loss of the nominal bonded link rate or at least 12ms for the TDM traffic. The exact definition is specific for each bonding scheme, e.g.

- 234 lost cells for the ATM bonding with 10Mbps nominal link rate
- 60 lost/discarded fragments for the Ethernet bonding with 10Mbps nominal link rate and fixed 192 Byte-long fragment size.
- 6 or more CRC4, one or more CRC6 or one or more CRC8 errors for the TDM bonding

This parameter is subject to inhibiting – see 4.2.4.

4.2.3 Unavailable Second (UAS)

An Unavailable Second for a G.998.x interface is a count of 1-second intervals for which the bonded link is unavailable. The G.998.x link becomes unavailable at the onset of 10 contiguous SESs. The 10 SESs are included in the unavailable time. Once unavailable, the G.998.x line becomes available at the onset of 10 contiguous seconds with no SESs. The 10 seconds with no SESs are excluded from unavailable time.

4.2.4 Inhibiting rules

- UAS parameter counts **MUST** not be inhibited.
- ES and SES **MUST** be inhibited during UAS. Inhibiting **MUST** be retroactive to the onset of unavailable time and **MUST** end retroactively to the end of unavailable time. Further information on inhibiting rules and how ES and SES are decremented can be found in RFC 2495 [9] and TL.231 [10].

4.2.5 Performance data storage

The BTU-C **SHOULD** maintain performance history buckets for each GBS port and its peer. The performance history buckets **MUST** include the total collected counts for the current 15-minute period, up to 96 previous 15-minute periods, current 24-hour period, and up to 7 previous 24-hour periods.

The beginning of each interval **SHOULD** be aligned to a 15 minute boundary of the wall clock.

There are situations in which performance data is unavailable. This mainly happens when the communication between the BTU-C and BTU-R is not fully operational. When all the data for a performance monitoring bucket is missing, suspect or known to be invalid, the BTU-C **MUST** report the bucket as invalid (i.e., by a dedicated interval-validity GET attribute added to each interval in the history database, or by removing all counters related to that invalid interval from the history database). In addition, if a bucket is determined to be invalid, the BTU-C **MUST NOT** produce notifications based upon the value of the counters in that bucket.

Note however that when the performance data is not fully available the BTU-C **MAY** still decide to report a performance monitoring bucket as valid but **MUST** also report the actual number of monitoring seconds during which valid performance data was available. This is useful for the first performance monitoring bucket of a performance monitoring process that was activated unaligned with a 15-minute boundary. It is also justified to keep the performance monitoring bucket valid when the performance data was unavailable only for a very short duration.

4.2.6 Performance data thresholds

All supported performance monitoring parameters (ES, SES, UAS) **SHOULD** have an individual 15-minute and 24-hour thresholds and corresponding threshold crossing alerts (notifications).

5 Management Framework Structure

This Technical Report defines a management framework that includes a common section with objects and attributes shared by all three xDSL Multi-pair Bonding technologies.

In addition to the common section, each technology has a specific management section.

The management of the underlying sub-layers (e.g. individual xDSL lines) is out of scope of this Technical Report.

5.1 Management Model

Management is viewed as a distributed application modeled as a set of interacting management processes. These processes are executed by systems within the open environment. A managing system executes a managing process that invokes management operations. A managed system executes a process that is receptive to these management operations and provides an interface to the resources to be managed. A managed object is the abstraction of a resource that represents its properties as seen by (and for the purpose of) management. Managed objects respond to a defined set of management operations. Managed objects are also capable of emitting a defined set of notifications.

Managed objects are defined in terms of four types of elements:

- *Attributes* - Data-like properties (as seen by management) of a managed object.
- *Actions* - Operations that a managing process may perform on an object or its attributes.
- *Notifications* - Unsolicited reports of events that may be generated by an object.
- *Behavior* - The way in which managed objects, attributes, and actions interact with the actual resources they model and with each other.

5.2 Containment

A containment relationship is a structuring relationship for managed objects in which the existence of a managed object is dependent on the existence of a containing managed object. The contained managed object is said to be the subordinate managed object, and the containing managed object the superior managed object. The containment relationship is used for naming managed objects. The local containment relationships among object classes are depicted in the entity relationship diagram below, which shows the names of the object classes and whether a particular containment relationship is one-to-one, one-to-many or many-to-one.

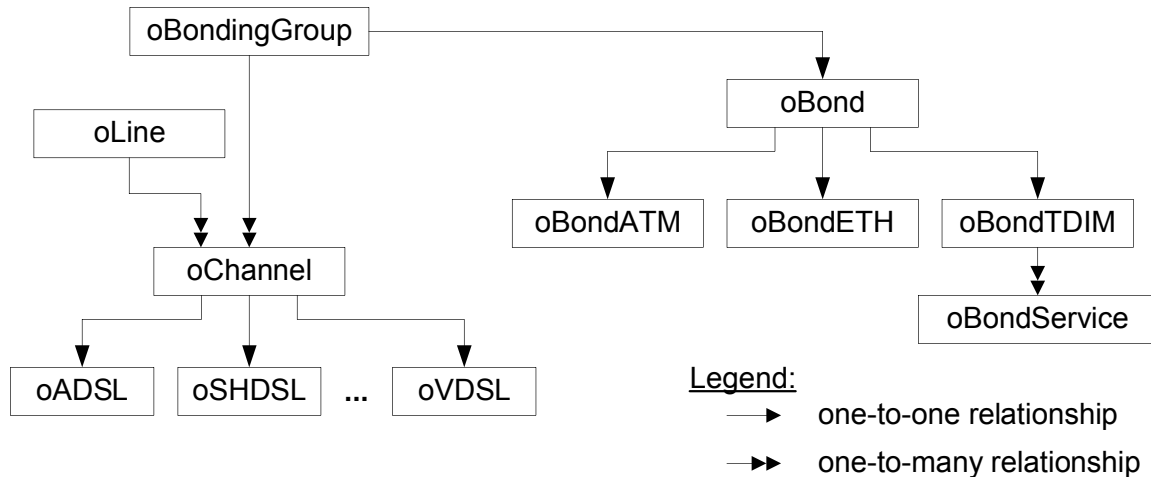

Figure 5-1: xDSL Bonding – Entity Relationship diagram

5.3 Managed Objects

The following managed objects are defined for the xDSL Bonding:

- oBondingGroup** the top-most managed object class of the xDSL Bonding containment tree shown in Figure 5-1:. Note that this managed object class may be contained within another superior managed object class (e.g. oPHYEntity for the Ethernet bonding). Such containment is expected, but is outside the scope of this Report. The oBondingGroup managed object class provides the management controls necessary to allow an instance of an xDSL Bonded link to be managed.
- oBond** this managed object class, contained within oBondingGroup, provides the Bonding Protocol Independent management controls, necessary to allow an instance of oBondingGroup to be managed.
- oBondATM** if implemented this managed object class, contained within oBond, provides the ATM xDSL Bonding Protocol Specific management controls, necessary to allow an instance of oBondingGroup to be managed.
- oBondETH** if implemented this managed object class, contained within oBond, provides the Ethernet xDSL Bonding Protocol Specific management controls, necessary to allow an instance of oBondingGroup to be managed.
- oBondTDIM** if implemented this managed object class, contained within oBond, provides the TDIM xDSL Bonding Protocol Specific management controls, necessary to allow an instance of oBondingGroup to be managed.

oBondService	if implemented this managed object class, contained within oBondTDIM, provides management controls for the service instance (Ethernet, ATM or TDM data stream) configuration, necessary to allow an instance of oBondTDIM to be managed.
oLine	this managed object class is contained within oBondingGroup. An instance of this managed object class is present for each xDSL line that is part of the bonded link represented by the oBondingGroup instance. This managed object class provides the basic management controls, necessary to allow an instance of an xDSL line to be managed, for the purposes of Bonding. Note that xDSL line management is out of scope of this Technical Report, most oLine managed objects simply map already existing objects defined in the relevant xDSL management specifications (e.g. HDSL2-SHDSL-LINE-MIB defined in RFC 4319 [6] and IF-MIB defined in RFC 2863 [5], if SNMP is used for the management) and provided for the purposes of completeness.
oChannel	this managed object class is contained within oLine. An instance of this managed object class is present for each TPS-TC provided by a particular xDSL line, represented by the oLine instance. For xDSL technologies supporting multiple bearer channels this managed object class represent a bearer channel ¹ . For xDSL technologies without such support, there is a one-to-one relationship between the oLine and oChannel. This managed object class provides the basic management controls, common to all xDSL technologies, necessary to allow an instance of an xDSL TPS-TC (channel) to be managed, for the purposes of Bonding.
oxDSL	this managed object class is contained within oChannel. An instance of this managed object class is present for each oChannel instance, providing the management controls specific to a particular xDSL technology, necessary to allow an instance of an xDSL TPS-TC (channel) to be managed, for the purposes of Bonding.

5.4 Capabilities

This Technical Report makes use of the concept of packages as defined in ISO/IEC 10165-4: 1992 [12], as a means of grouping behavior, attributes, actions, and notifications within a managed object class definition. Packages may either be mandatory, or be conditional, that is to say, present if a given condition is true. Within this Technical Report capabilities are defined, each of which corresponds to a set of packages, which are components of a number of managed object class definitions and which share the same condition for presence. The capabilities and packages for the xDSL Bonding are specified in the table below:

¹ In case pre-emption is used on a bearer channel, oChannel represents one (out of the two) logical channel of the bearer channel.

Table 5-1: xDSL Multi-pair Bonding Management Capabilities

Object Name	Object Type	Operations Supported	ATM Bonding			Ethernet Bonding			TDIM Bonding			
			Basic package (mandatory)	PM (optional)	MBS (optional)	Basic package (mandatory)	PM (optional)	BACP (optional)	Basic package (mandatory)	PM (optional)	MBS (optional)	FEC (optional)
oBondingGroup												
aGroupID	attribute	GET	x			x			x			
aGroupBondSchemesSupported	attribute	GET	x			x			x			
aGroupPeerBondSchemesSupported	attribute	GET	x			x			x			
aGroupAdminBondScheme	attribute	GET-SET			x			x			x	
aGroupPeerAdminBondScheme	attribute	GET-SET			x			x			x	
aGroupOperBondScheme	attribute	GET	x			x			x			
aGroupPeerOperBondScheme	attribute	GET	x			x			x			
aGroupEnd	attribute	GET	x			x			x			
aGroupOperState	attribute	GET	x			x			x			
aGroupStatus	attribute	GET	x			x			x			
aGroupCapacity	attribute	GET	x			x			x			
aGroupPeerCapacity	attribute	GET	x			x			x			
aGroupUpRate	attribute	GET	x			x			x			
aGroupDownRate	attribute	GET	x			x			x			
aGroupNumChannels	attribute	GET	x			x			x			
aGroupName	attribute	GET-SET	x			x			x			
aGroupAdminState	attribute	GET-SET	x			x			x			
aGroupDiscoveryCode	attribute	GET-SET				x			x			
aGroupTargetUpRate	attribute	GET-SET	x			x			x			
aGroupTargetDownRate	attribute	GET-SET	x			x			x			
aGroupThreshLowUpRate	attribute	GET-SET	x			x			x			
aGroupThreshLowDownRate	attribute	GET-SET	x			x			x			
aGroupLowRateCrossingEnable	attribute	GET-SET	x			x			x			
nGroupLowUpRateCrossing	notification		x			x			x			
nGroupLowDownRateCrossing	notification		x			x			x			
aGroupLinkUpDownEnable	attribute	GET-SET	x			x			x			
nGroupLinkUp	notification		x			x			x			

Object Name	Object Type	Operations Supported	ATM Bonding			Ethernet Bonding			TDIM Bonding			
			Basic package (mandatory)	PM (optional)	MBS (optional)	Basic package (mandatory)	PM (optional)	BACP (optional)	Basic package (mandatory)	PM (optional)	MBS (optional)	FEC (optional)
nGroupLinkDown	notification		X			X			X			
aGroupPerfES	attribute	GET		X			X			X		
aGroupPerfSES	attribute	GET		X			X			X		
aGroupPerfUAS	attribute	GET		X			X			X		
aGroupPerf15MinValidIntervals	attribute	GET		X			X			X		
aGroupPerf15MinInvalidIntervals	attribute	GET		X			X			X		
aGroupPerfCurr15MinTimeElapsed	attribute	GET		X			X			X		
aGroupPerfCurr15MinES	attribute	GET		X			X			X		
aGroupPerfCurr15MinSES	attribute	GET		X			X			X		
aGroupPerfCurr15MinUAS	attribute	GET		X			X			X		
aGroupPerfTcaEnable	attribute	GET-SET		X			X			X		
aGroupPerfThreshold15MinES	attribute	GET-SET		X			X			X		
aGroupPerfThreshold15MinSES	attribute	GET-SET		X			X			X		
aGroupPerfThreshold15MinUAS	attribute	GET-SET		X			X			X		
nGroupPerfTca15MinES	notification			X			X			X		
nGroupPerfTca15MinSES	notification			X			X			X		
nGroupPerfTca15MinUAS	notification			X			X			X		
aGroupPerf1DayValidIntervals	attribute	GET		X			X			X		
aGroupPerf1DayInvalidIntervals	attribute	GET		X			X			X		
aGroupPerfCurr1DayTimeElapsed	attribute	GET		X			X			X		
aGroupPerfCurr1DayES	attribute	GET		X			X			X		
aGroupPerfCurr1DaySES	attribute	GET		X			X			X		
aGroupPerfCurr1DayUAS	attribute	GET		X			X			X		
aGroupPerfThreshold1DayES	attribute	GET-SET		X			X			X		
aGroupPerfThreshold1DayS	attribute	GET-SET		X			X			X		

Object Name	Object Type	Operations Supported	ATM Bonding			Ethernet Bonding			TDIM Bonding				
			Basic package (mandatory)	PM (optional)	MBS (optional)	Basic package (mandatory)	PM (optional)	BACP (optional)	Basic package (mandatory)	PM (optional)	MBS (optional)	FEC (optional)	
ES													
aGroupPerfThreshold1DayUAS	attribute	GET-SET		X			X				X		
nGroupPerfTca1DayES	notification			X			X				X		
nGroupPerfTca1DaySES	notification			X			X				X		
nGroupPerfTca1DayUAS	notification			X			X				X		
aGroupPerf15MinIntervalNumber	attribute	GET		X			X				X		
aGroupPerf15MinIntervalValid	attribute	GET		X			X				X		
aGroupPerf15MinIntervalES	attribute	GET		X			X				X		
aGroupPerf15MinIntervalSES	attribute	GET		X			X				X		
aGroupPerf15MinIntervalUAS	attribute	GET		X			X				X		
aGroupPerf1DayIntervalNumber	attribute	GET		X			X				X		
aGroupPerf1DayIntervalValid	attribute	GET		X			X				X		
aGroupPerf1DayIntervalMiniSecs	attribute	GET		X			X				X		
aGroupPerf1DayIntervalES	attribute	GET		X			X				X		
aGroupPerf1DayIntervalSES	attribute	GET		X			X				X		
aGroupPerf1DayIntervalUAS	attribute	GET		X			X				X		
oBondATM													
aIMARxLostCells	attribute	GET	X										
aIMAPeerRxLostCells	attribute	GET	X										
aIMAMaxUpDiffDelay	attribute	GET	X										
aIMAMaxDownDiffDelay	attribute	GET	X										
aIMAUpDiffDelayTolerance	attribute	GET-SET	X										
aIMADownDiffDelayTolerance	attribute	GET-SET	X										
aIMADiffDelayToleranceExceededEnable	attribute	GET-SET	X										
nIMAUpDiffDelayTolerance	notification		X										

Object Name	Object Type	Operations Supported	ATM Bonding			Ethernet Bonding			TDIM Bonding				
			Basic package (mandatory)	PM (optional)	MBS (optional)	Basic package (mandatory)	PM (optional)	BACP (optional)	Basic package (mandatory)	PM (optional)	MBS (optional)	FEC (optional)	
Exceeded													
nIMADownDiffDelayToleranceExceeded	notification		x										
oBondETH													
aEthBACPSupported	attribute	GET				x							
aEthAdminCP	attribute	GET-SET						x					
aEthOperCP	attribute	GET						x					
aEthTcAdminType	attribute	GET-SET				x							
aEthTcOperType	attribute	GET				x							
aEthTcTypesSupported	attribute	GET				x							
aEthRxErrors	attribute	GET				x							
aEthRxSmallFragments	attribute	GET				x							
aEthRxFragments	attribute	GET				x							
aEthRxBadFragments	attribute	GET				x							
aEthRxLostFragments	attribute	GET				x							
aEthRxLostStarts	attribute	GET				x							
aEthRxLostEnds	attribute	GET				x							
aEthRxOverflows	attribute	GET				x							
oBondTDIM													
aCRC4Errors	attribute	GET								x			
aCRC6Errors	attribute	GET								x			
aCRC8Errors	attribute	GET								x			
aFECSupported	attribute	GET								x			
aFECAdminState	attribute	GET-SET											x
aFECOperState	attribute	GET											x
aFECWordSize	attribute	GET-SET											x
aFECRedundancySize	attribute	GET-SET											x
aFECInterleaverType	attribute	GET-SET											x
aFECInterleaverDepth	attribute	GET-SET											x
aFECMaxWordSize	attribute	GET											x
aFECMaxRedundancySize	attribute	GET											x
aFECInterleaverTypesSupported	attribute	GET											x
aFECMaxInterleaverDepth	attribute	GET											x
oTDIMService													
aServiceID	attribute	GET								x			

Object Name	Object Type	Operations Supported	ATM Bonding			Ethernet Bonding			TDIM Bonding			
			Basic package (mandatory)	PM (optional)	MBS (optional)	Basic package (mandatory)	PM (optional)	BACP (optional)	Basic package (mandatory)	PM (optional)	MBS (optional)	FEC (optional)
aServiceIfIndex	attribute	GET							X			
aServiceType	attribute	GET-SET							X			
aServiceSize	attribute	GET-SET							X			
aServiceOperState	attribute	GET										
aServiceUpDownEnable	attribute	GET-SET							X			
nServiceUp	notification								X			
nServiceDown	notification								X			
oLine												
aLineID	attribute	GET	X			X			X			
aLineType	attribute	GET	X			X			X			
aLineOperState	attribute	GET	X			X			X			
aLineStatus	attribute	GET	X			X			X			
aLineEnd	attribute	GET	X			X			X			
aLineAdminState	attribute	GET-SET	X			X			X			
aLineRemoteDiscoveryCode	attribute	GET-SET				X			X			
aLineUpDownEnable	attribute	GET-SET	X			X			X			
nLineUp	notification		X			X			X			
nLineDown	notification		X			X			X			
oChannel												
aChannelID	attribute	GET	X			X			X			
aChannelGroupID	attribute	GET	X			X			X			
aChannelEligibleGroupID	attribute	GET-SET						X				
aChannelEligibleStreamID	attribute	GET-SET						X				
aChannelType	attribute	GET	X			X			X			
aChannelOperState	attribute	GET	X			X			X			
aChannelStatus	attribute	GET	X			X			X			
aChannelPtmTcRxCodingViolations	attribute	GET						X				
aChannelPtmTcRxCrcErrors	attribute	GET						X				

5.5 Element Definitions for the Managed objects

5.5.1 oBondingGroup

5.5.1.1 aGroupID

ATTRIBUTE

SYNTAX:

INTEGER

DESCRIPTION:

A read-only value to uniquely identify a bonding group.

When SNMP is used to manage the BTU, the aGroupID is represented by the IF-MIB ifIndex object.

5.5.1.2 aGroupBondSchemesSupported

ATTRIBUTE

SYNTAX:

BITS { g9981, g9982, g9983 }

DESCRIPTION:

A read-only bitmap of the bonding schemes supported by the G.998.x interface.

The bit positions are:

- g9981 Indicates that the bonding group supports G.998.1 ATM-based bonding.
- g9982 Indicates that the bonding group supports G.998.2 Ethernet-based bonding.
- g9983 Indicates that the bonding group supports G.998.3 TDIM-based bonding.

5.5.1.3 aGroupPeerBondSchemesSupported

ATTRIBUTE

SYNTAX:

BITS {g9981, g9982, g9983}

DESCRIPTION:

A read-only bitmap of the bonding schemes supported by the peer device. The bit positions are:

- g9981 – indicates that the peer device supports G.998.1 ATM-based bonding.
- g9982 – indicates that the peer device supports G.998.2 Ethernet-based bonding.
- g9983 – indicates that the peer device supports G.998.3 TDIM-based bonding.

An all-zero value is returned when the peer cannot be reached or does not support any kind of bonding.

5.5.1.4 aGroupOperBondScheme

ATTRIBUTE

SYNTAX:

ENUM { g9981, g9982, g9983 }

DESCRIPTION:

A read-only value to identify currently operating bonding scheme. A value of "g9981" indicates that the bonding group uses G.998.1 ATM-based bonding. A value of "g9982" indicates that the used bonding scheme is G.998.2 Ethernet-based.

A value of "g9983" indicates that the bonding group uses G.998.3 TDIM-based bonding.

When SNMP is used to manage the BTU, the IF-MIB ifType object indicates that the bonded interface is operating under one of the G.998 bonding schemes.

5.5.1.5 aGroupPeerOperBondScheme

ATTRIBUTE

SYNTAX:

ENUM {unknown, g9981, g9982, g9983}

DESCRIPTION:

A read-only value to identify the currently operating bonding scheme used by the peer unit . A value of "g9981" indicates that the peer unit uses G.998.1 ATM-based bonding. A value of "g9982" indicates that the used bonding scheme is G.998.2 Ethernet-based. A value of "g9983" indicates that the bonding group uses G.998.3 TDIM-based bonding. A value of "unknown" indicates that the peer cannot be reached.

5.5.1.6 aGroupAdminBondScheme

ATTRIBUTE

SYNTAX:

ENUM { g9981, g9982, g9983}

DESCRIPTION:

A read-write value specifying the desired bonding scheme. A value of "g9981" instructs the bonding group to use G.998.1 ATM-based bonding. A value of "g9982" instructs it to use G.998.2 Ethernet-based bonding. A value of "g9983" instructs it to use G.998.3 TDIM-based bonding.

This attribute **MUST** be supported on interfaces supporting multiple bonding schemes.

5.5.1.7 aGroupPeerAdminBondScheme

ATTRIBUTE

SYNTAX:

ENUM {g9981, g9982, g9983}

DESCRIPTION:

A read-write value specifying the desired bonding scheme used by the peer unit . A value of "g9981" instructs the peer unit to use G.998.1 ATM-based bonding. A value of "g9982" instructs it to use G.998.2 Ethernet-based bonding. A value of "g9983" instructs it to use G.998.3 TDIM-based bonding.

This attribute **SHOULD** be supported on interfaces supporting multiple bonding schemes.

5.5.1.8 aGroupOperState

ATTRIBUTE

SYNTAX:

ENUM { down, init, up}

DESCRIPTION:

A read-only value indicating current operational state of a bonding group. A value of "down" indicates that the bonding group is operationally down. A value of "init"

indicates that the group is initializing. A value of "up" indicates that the group is operationally up and is able to pass traffic.

When SNMP is used to manage the BTU, the aGroupOperState is represented by the IF-MIB ifOperStatus object.

5.5.1.9 aGroupStatus

ATTRIBUTE

SYNTAX:

BITS { noPeer, peerPowerLoss, peerBondSchemeMismatch, lowRate }

DESCRIPTION:

A read-only value indicating current fault status of a bonding group. This is a bitmap of possible faults. The bit positions are:

noPeer	Indicates that the peer physical layer is unreachable (e.g., no BCE is associated with this GBS, no BCE is operationally 'up').
peerPowerLoss	Indicates that the local device received a "dying gasp" message (preceding a loss-of-power) from the peer device.
peerBondSchemeMismatch	Indicates that the operating bonding scheme of the peer port is different from the local one.
lowRate	Indicates that either aGroupUpRate or aGroupDownRate value has dropped to or below aGroupThreshLowUpRate or aGroupThreshLowDownRate, respectively.

5.5.1.10 aGroupName

ATTRIBUTE

SYNTAX:

A PrintableString, 255 characters max.

DESCRIPTION:

A human-readable text string containing a locally significant name for the bonding group. This string is read-write.

When SNMP is used to manage the BTU, the aGroupName is represented by the IF-MIB ifName object.

5.5.1.11 aGroupEnd

ATTRIBUTE

SYNTAX:

ENUM {subscriber, office, unknown}

DESCRIPTION:

A read-only value to uniquely identify a sub-type of the G.998.x port. A value of "subscriber" indicates that the port operates as GBS-R (Remote Terminal side). A value of "office" indicates that the port operates as GBS-C (Central Office side). A value of "unknown" indicates that the port's sub-type cannot be determined.

5.5.1.12 aGroupCapacity

ATTRIBUTE

SYNTAX:

INTEGER

DESCRIPTION:

The aGroupCapacity is the number of Channels that can be aggregated by a particular G.998.x port (GBS). Valid range is 1-32. Within each G.998.x port, the BCEs are uniquely numbered in the range from 1 to aGroupCapacity. Some BCEs may not be present in a given GBS instance, in which case the actual number of BCEs present is less than aGroupCapacity. The number of BCEs present is never greater than aGroupCapacity.

5.5.1.13 aGroupPeerCapacity

ATTRIBUTE

SYNTAX:

INTEGER

DESCRIPTION:

The aGroupPeerCapacity is the number of Channels that can be aggregated by the peer G.998.x port. Valid range is 0-32. Within each G.998.x port, the BCEs are uniquely numbered in the range from 1 to aGroupPeerCapacity. The value of zero is returned when the peer Bonding Capacity is unknown (e.g. peer cannot be reached). Some BCEs may not be present in a given GBS instance, in which case the actual number of BCEs present is less than aGroupPeerCapacity. The number of BCEs present is never greater than aGroupPeerCapacity. This attribute is read-only.

5.5.1.14 aGroupNumChannels

ATTRIBUTE

SYNTAX:

INTEGER

DESCRIPTION:

A number of Channels that is actually aggregated/bonded by a particular G.998.x port (GBS). Valid range is 1-32. Within each G.998.x port, the BCEs are uniquely numbered in the range from 1 to aGroupCapacity. Some BCEs may not be present in a given GBS instance, in which case aGroupNumChannels is less than aGroupCapacity. The number of BCEs present is never greater than aGroupCapacity. This attribute is read-only.

5.5.1.15 aGroupUpRate

ATTRIBUTE

SYNTAX:

INTEGER

DESCRIPTION:

The aGroupUpRate is the current operating data rate of the GBS in the upstream direction, in bits per second. This attribute is read-only.

5.5.1.16 aGroupDownRate

ATTRIBUTE

SYNTAX:

INTEGER

DESCRIPTION:

The aGroupDownRate is the current operating data rate of the GBS in the downstream direction, in bits per second. This attribute is read-only.

5.5.1.17 aGroupTargetUpRate

ATTRIBUTE

SYNTAX:

INTEGER

DESCRIPTION:

A desired operating data rate of the GBS in the upstream direction, in bits per second. A value of zero instructs the GBS to provide "best effort" upstream data rate. This attribute is read-write.

This object maps to the *Upstream Maximum aggregate data rate* parameter in G.998.1

5.5.1.18 aGroupTargetDownRate

ATTRIBUTE

SYNTAX:

INTEGER

DESCRIPTION:

A desired operating data rate of the GBS in the downstream direction, in bits per second. A value of zero instructs the GBS to provide "best effort" downstream data rate. This attribute is read-write.

This object maps to the *Downstream Maximum aggregate data rate* parameter in G.998.1

5.5.1.19 aGroupAdminState

ATTRIBUTE

SYNTAX:

ENUM { down, up }

DESCRIPTION:

A read-write value, indicating current desired status of a bonding group. A value of "down" instructs the bonding group to be operationally down. A value of "up" instructs the group to be operationally up and is able to pass traffic.

When SNMP is used to manage the BTU, the aGroupAdminState is represented by the IF-MIB ifAdminStatus object.

5.5.1.20 aGroupDiscoveryCode

ATTRIBUTE

SYNTAX:

OCTET STRING (6)

DESCRIPTION:

A unique 6-octet long identifier used by the OPTIONAL G.hs-based Discovery function.

This object MUST be instantiated for the GBS-C before writing operations on the aLineRemoteDiscoveryCode (Set_if_Clear and Clear_if_Same) are performed by BCEs associated with the GBS.

The initial value of this object for -R subtype ports after reset is all zeroes. For -R subtype ports, the value of this object cannot be changed directly. This value may

be changed as a result of writing operation on the `aLineRemoteDiscoveryCode` object of remote BCE of –O subtype, connected to one of the local BCEs associated with the GBS.

Discovery MUST be performed when the link is Down.

This read-write object maps to the local Discovery Code variable in 802.3-2005 PAF.

5.5.1.21 aGroupThreshLowUpRate

ATTRIBUTE

SYNTAX:

INTEGER

DESCRIPTION:

A desired G.998.x port low upstream rate crossing alarm threshold, in bits per sec.

When the current value of `aGroupUpRate` for this port reaches/drops below or exceeds this threshold, an `aGroupLowUpRateCrossing` notification MAY be generated if enabled by `aGroupLowRateCrossingEnable`.

This attribute is read-write for the GBS-C and irrelevant for the GBS-R ports.

This object maps to the *Upstream Minimum aggregate data rate* parameter in G.998.1

5.5.1.22 aGroupThreshLowDownRate

ATTRIBUTE

SYNTAX:

INTEGER

DESCRIPTION:

A desired G.998.x port low upstream rate crossing alarm threshold, in bits per sec.

When the current value of `aGroupDownRate` for this port reaches/drops below or exceeds this threshold, an `aGroupLowDownRateCrossing` notification MAY be generated if enabled by `aGroupLowRateCrossingEnable`.

This attribute is read-write for the GBS-C and irrelevant for the GBS-R ports.

This object maps to the *Upstream Minimum aggregate data rate* parameter in G.998.1

5.5.1.23 aGroupLowRateCrossingEnable

ATTRIBUTE

SYNTAX:

BOOLEAN

DESCRIPTION:

Indicates whether `nGroupLowUpRateCrossing` and `nGroupLowDownRateCrossing` notifications should be generated for the GBS port. Value of true (1) indicates that the notifications are enabled. Value of false (2) indicates that the notifications are disabled.

This attribute is read-write for the GBS-C and irrelevant for the GBS-R ports.

5.5.1.24 nGroupLowUpRateCrossing

NOTIFICATION

SYNTAX:

SEQUENCE OF { aGroupUpRate, aGroupThreshLowUpRate }

DESCRIPTION:

This notification indicates that the G.998.x port upstream data rate has reached/dropped below or exceeded the low upstream rate threshold, specified by aGroupThreshLowUpRate.

This notification MAY be sent for the GBS-C ports while the port is up, on the crossing event in both directions: from normal (rate is above the threshold) to low (rate equals the threshold or below it) and from low to normal. This notification is not applicable to the GBS-R ports.

Generation of this notification is controlled by the aGroupLowRateCrossingEnable attribute.

5.5.1.25 nGroupLowDownRateCrossing

NOTIFICATION

SYNTAX:

SEQUENCE OF { aGroupDownRate, aGroupThreshLowDownRate }

DESCRIPTION:

This notification indicates that the G.998.x port downstream data rate has reached/dropped below or exceeded the low downstream rate threshold, specified by aGroupThreshLowDownRate.

This notification MAY be sent for the GBS-C ports while the port is up, on the crossing event in both directions: from normal (rate is above the threshold) to low (rate equals the threshold or below it) and from low to normal. This notification is not applicable to the GBS-R ports.

Generation of this notification is controlled by the aGroupLowRateCrossingEnable attribute.

5.5.1.26 aGroupLinkUpDownEnable

ATTRIBUTE

SYNTAX:

BOOLEAN

DESCRIPTION:

A read-write value indicating whether nGroupLinkUp and nGroupLinkDown notifications should be generated for the GBS port. Value of true (1) indicates that the notifications are enabled. Value of false (2) indicates that the notifications are disabled.

5.5.1.27 nGroupLinkUp

NOTIFICATION

SYNTAX:

SEQUENCE OF { aGroupAdminState, aGroupStatus }

DESCRIPTION:

This notification indicates that the G.998.x port has transitioned to an "up" status, as specified by aGroupStatus.

When SNMP is used to manage the BTU, the nGroupLinkUp is represented by the IF-MIB linkUp notification.

Generation of this notification is controlled by the aGroupLinkUpDownEnable attribute.

5.5.1.28 nGroupLinkDown

NOTIFICATION

SYNTAX:

SEQUENCE OF { aGroupAdminState, aGroupStatus }

DESCRIPTION:

This notification indicates that the G.998.x port has transitioned to a "down" status, as specified by aGroupStatus.

When SNMP is used to manage the BTU, the nGroupLinkDown is represented by the IF-MIB linkDown notification.

Generation of this notification is controlled by the aGroupLinkUpDownEnable attribute.

5.5.1.29 aGroupPerfES

ATTRIBUTE

SYNTAX:

Generalized non-resettable counter

DESCRIPTION:

A read-only count of Errored Seconds (ES) on the GBS since the BTU was last restarted. See 4.2.1 for the definition of ES.

5.5.1.30 aGroupPerfSES

ATTRIBUTE

SYNTAX:

Generalized non-resettable counter

DESCRIPTION:

A read-only count of Severely Errored Seconds (SES) on the GBS since the BTU was last restarted. See 4.2.2 for the definition of SES.

5.5.1.31 aGroupPerfUAS

ATTRIBUTE

SYNTAX:

Generalized non-resettable counter

DESCRIPTION:

A read-only count of Unavailable Seconds (UAS) on the GBS since the BTU was last restarted. See 4.2.3 for the definition of UAS.

5.5.1.32 aGroupPerf15MinValidIntervals

ATTRIBUTE

SYNTAX:

INTEGER (0..96)

DESCRIPTION:

A read-only attribute reporting the number of 15 minutes intervals for which data was collected. The value of this object will be 96 or the maximum number of 15 minutes history intervals collected by the implementation unless the measurement was (re-)started recently, in which case the value will be the number of complete 15 minutes intervals for which there are at least some data.

In certain cases it is possible that some intervals are unavailable. In this case, this object reports the maximum interval number for which data is available.

5.5.1.33 aGroupPerf15MinInvalidIntervals

ATTRIBUTE

SYNTAX:

INTEGER (0..96)

DESCRIPTION:

A read-only attribute reporting the number of 15 minutes intervals for which data was not always available. The value will typically be zero except in cases where the data for some intervals are not available.

5.5.1.34 aGroupPerfCurr15MinTimeElapsed

ATTRIBUTE

SYNTAX:

Generalized non-resettable counter

DESCRIPTION:

A read-only number of seconds that have elapsed since the beginning of the current 15-minute performance history interval.

5.5.1.35 aGroupPerfCurr15MinES

ATTRIBUTE

SYNTAX:

Generalized non-resettable counter

DESCRIPTION:

A read-only count of Errored Seconds (ES) on the GBS in the current 15-minute performance history interval. See 4.2.1 for the definition of ES.

5.5.1.36 aGroupPerfCurr15MinSES

ATTRIBUTE

SYNTAX:

Generalized non-resettable counter

DESCRIPTION:

A read-only count of Severely Errored Seconds (SES) on the GBS in the current 15-minute interval. See 4.2.2 for the definition of SES.

5.5.1.37 aGroupPerfCurr15MinUAS

ATTRIBUTE

SYNTAX:

Generalized non-resettable counter

DESCRIPTION:

A read-only count of Unavailable Seconds (UAS) on the GBS in the current 15-minute performance history interval. See 4.2.3 for the definition of UAS.

5.5.1.38 aGroupPerfTcaEnable

ATTRIBUTE

SYNTAX:

BOOLEAN

DESCRIPTION:

A read-write value indicating whether the nGroupPerfTca* set of notifications should be generated for a GBS port. Value of true (1) indicates that the notifications are enabled. Value of false (2) indicates that the notifications are disabled.

5.5.1.39 aGroupPerfThreshold15MinES

ATTRIBUTE

SYNTAX:

INTEGER (0|1..900)

DESCRIPTION:

A desired threshold for the number of Errored Seconds (ES) within any given 15-minute performance data collection interval. If the number of ESs in a particular 15-minute collection interval reaches or exceeds this value, a nGroupPerfTca15MinES notification MAY be generated if enabled by aGroupPerfTcaEnable. At most one notification can be sent per interval. Setting this attribute to zero (default) effectively disables nGroupPerfTca15MinES notification.

This attribute is read-write.

5.5.1.40 aGroupPerfThreshold15MinSES

ATTRIBUTE

SYNTAX:

INTEGER (0|1..900)

DESCRIPTION:

A desired threshold for the number of Severely Errored Seconds (SES) within any given 15-minute performance data collection interval. If the number of SESs in a particular 15-minute collection interval reaches or exceeds this value, a nGroupPerfTca15MinSES notification MAY be generated if enabled by aGroupPerfTcaEnable. At most one notification can be sent per interval. Setting this attribute to zero (default) effectively disables nGroupPerfTca15MinSES notification.

This attribute is read-write.

5.5.1.41 aGroupPerfThreshold15MinUAS

ATTRIBUTE

SYNTAX:

INTEGER (0|1..900)

DESCRIPTION:

A desired threshold for the number of Unavailable Seconds (UAS) within any given 15-minute performance data collection interval. If the number of UASs in a particular 15-minute collection interval reaches or exceeds this value, a nGroupPerfTca15MinUAS notification MAY be generated if enabled by aGroupPerfTcaEnable. At most one notification can be sent per interval. Setting this attribute to zero (default) effectively disables nGroupPerfTca15MinUAS notification.

This attribute is read-write.

5.5.1.42 nGroupPerfTca15MinES

NOTIFICATION

SYNTAX:

SEQUENCE OF {aGroupPerfCurr15MinES, aGroupPerfThreshold15MinES}

DESCRIPTION:

This notification indicates that the Errored Seconds threshold , specified by aGroupPerfThreshold15MinES, has been reached or exceeded for the GPS port. Generation of this notification is controlled by aGroupPerfTcaEnable and aGroupPerfThreshold15MinES attributes.

5.5.1.43 nGroupPerfTca15MinSES

NOTIFICATION

SYNTAX:

SEQUENCE OF {aGroupPerfCurr15MinSES, aGroupPerfThreshold15MinSES}

DESCRIPTION:

This notification indicates that the Severely Errored Seconds threshold , specified by aGroupPerfThreshold15MinSES, has been reached or exceeded for the GPS port.

Generation of this notification is controlled by aGroupPerfTcaEnable and aGroupPerfThreshold15MinSES attributes.

5.5.1.44 nGroupPerfTca15MinUAS

NOTIFICATION

SYNTAX:

SEQUENCE OF {aGroupPerfCurr15MinUAS, aGroupPerfThreshold15MinUAS}

DESCRIPTION:

This notification indicates that the Unavailable Seconds threshold , specified by aGroupPerfThreshold15MinUAS, has been reached or exceeded for the GPS port.

Generation of this notification is controlled by aGroupPerfTcaEnable and aGroupPerfThreshold15MinUASattributes.

5.5.1.45 aGroupPerf1DayValidIntervals

ATTRIBUTE

SYNTAX:

INTEGER (0..7)

DESCRIPTION:

A read-only attribute reporting the number of 1-day intervals for which data was collected. The value of this object will be 7 or the maximum number of 1-day history intervals collected by the implementation unless the measurement was (re-)started recently, in which case the value will be the number of complete 1-day intervals for which there are at least some data.

In certain cases it is possible that some intervals are unavailable. In this case, this object reports the maximum interval number for which data is available.

5.5.1.46 aGroupPerf1DayInvalidIntervals

ATTRIBUTE

SYNTAX:

INTEGER (0..7)

DESCRIPTION:

A read-only attribute reporting the number of 1-day intervals for which data was not always available. The value will typically be zero except in cases where the data for some intervals are not available.

5.5.1.47 aGroupPerfCurr1DayTimeElapsed

ATTRIBUTE

SYNTAX:

Generalized non-resettable counter

DESCRIPTION:

A read-only number of seconds that have elapsed since the beginning of the current 24-hour (1-day) performance history interval.

5.5.1.48 aGroupPerfCurr1DayES

ATTRIBUTE

SYNTAX:

Generalized non-resettable counter

DESCRIPTION:

A read-only count of Errored Seconds (ES) on the GBS since the beginning of the current 1-day performance history interval. See 4.2.1 for the definition of ES.

5.5.1.49 aGroupPerfCurr1DaySES

ATTRIBUTE

SYNTAX:

Generalized non-resettable counter

DESCRIPTION:

A read-only count of Severely Errored Seconds (SES) on the GBS since the beginning of the current 1-day performance history interval. See 4.2.2 for the definition of SES.

5.5.1.50 aGroupPerfCurr1DayUAS

ATTRIBUTE

SYNTAX:

Generalized non-resettable counter

DESCRIPTION:

A read-only count of Unavailable Seconds (UAS) on the GBS since the beginning of the current 1-day performance history interval. See 4.2.3 for the definition of UAS.

5.5.1.51 aGroupPerfThreshold1DayES

ATTRIBUTE

SYNTAX:

INTEGER (0|1..86400)

DESCRIPTION:

A desired threshold for the number of Errored Seconds (ES) within any given 1-day performance data collection interval. If the number of errored seconds in a particular 1-day collection interval reaches or exceeds this value, a nGroupPerfTca1DayES notification MAY be generated if enabled by aGroupPerfTcaEnable. At most one notification can be sent per interval. Setting this attribute to zero (default) effectively disables nGroupPerfTca1DayES notification.

This attribute is read-write

5.5.1.52 aGroupPerfThreshold1DaySES

ATTRIBUTE

SYNTAX:

INTEGER (0|1..86400)

DESCRIPTION:

A desired threshold for the number of Severely Errored Seconds (SES) within any given 1-day performance data collection interval. If the number of SESs in a particular 1-day collection interval reaches or exceeds this value, a nGroupPerfTca1DaySES notification MAY be generated if enabled by aGroupPerfTcaEnable. At most one notification can be sent per interval. Setting this attribute to zero (default) effectively disables nGroupPerfTca1DaySES notification.

This attribute is read-write

5.5.1.53 aGroupPerfThreshold1DayUAS

ATTRIBUTE

SYNTAX:

INTEGER (0|1..86400)

DESCRIPTION:

A desired threshold for the number of Unavailable Seconds (UAS) within any given 1-day performance data collection interval. If the number of UASs in a particular 1-day collection interval reaches or exceeds this value, a nGroupPerfTca1DayUAS notification MAY be generated if enabled by aGroupPerfTcaEnable. At most one notification can be sent per interval. Setting this attribute to zero (default) effectively disables nGroupPerfTca1DayUAS notification.

This attribute is read-write.

5.5.1.54 nGroupPerfTca1DayES

NOTIFICATION

SYNTAX:

SEQUENCE OF {aGroupPerfCurr1DayES, aGroupPerfThreshold1DayES}

DESCRIPTION:

This notification indicates that the Errored Seconds threshold , specified by aGroupPerfThreshold1DayES, has been reached or exceeded for the GPS port. Generation of this notification is controlled by aGroupPerfTcaEnable and aGroupPerfThreshold1DayES attributes.

5.5.1.55 nGroupPerfTca1DaySES

NOTIFICATION

SYNTAX:

SEQUENCE OF {aGroupPerfCurr1DaySES, aGroupPerfThreshold1DaySES}

DESCRIPTION:

This notification indicates that the Severely Errored Seconds threshold , specified by aGroupPerfThreshold1DaySES, has been reached or exceeded for the GPS port. Generation of this notification is controlled by aGroupPerfTcaEnable and aGroupPerfThreshold1DaySES attributes.

5.5.1.56 nGroupPerfTca1DayUAS

NOTIFICATION

SYNTAX:

SEQUENCE OF {aGroupPerfCurr1DayUAS, aGroupPerfThreshold1DayUAS}

DESCRIPTION:

This notification indicates that the Unavailable Seconds threshold, specified by aGroupPerfThreshold1DayUAS, has been reached or exceeded for the GPS port. Generation of this notification is controlled by aGroupPerfTcaEnable and aGroupPerfThreshold1DayUAS attributes.

5.5.1.57 aGroupPerf15MinIntervalNumber

ATTRIBUTE

SYNTAX:

INTEGER (1..96)

DESCRIPTION:

A read-only number of the 15-minute performance history interval. Interval 1 is the most recent previous interval; interval 96 is 24 hours ago. Intervals 2..96 are OPTIONAL.

5.5.1.58 aGroupPerf15MinIntervalValid

ATTRIBUTE

SYNTAX:

BOOLEAN

DESCRIPTION:

A read-only attribute indicating whether or not this history bucket contains valid data. Valid bucket is reported as true (1) and invalid bucket as false (2). If this history bucket is invalid the BTU-C MUST NOT produce notifications based upon the value of the counters in this bucket. Note that an implementation may decide not to store invalid history buckets in its data base. In such case this object is not required as only valid history buckets are available while invalid history buckets are simply not in the data base.

5.5.1.59 aGroupPerf15MinIntervalES

ATTRIBUTE

SYNTAX:

Generalized non-resettable counter

DESCRIPTION:

A read-only count of Errored Seconds (ES) on the GBS during the 15-minute performance history interval, indexed by the aGroupPerf15MinIntervalNumber. See 4.2.1 for the definition of ES.

5.5.1.60 aGroupPerf15MinIntervalSES

ATTRIBUTE

SYNTAX:

Generalized non-resettable counter

DESCRIPTION:

A read-only count of Severely Errored Seconds (SES) on the GBS during the 15-minute performance history interval, indexed by the `aGroupPerf15MinIntervalNumber`.
See 4.2.2 for the definition of SES.

5.5.1.61 *aGroupPerf15MinIntervalUAS*

ATTRIBUTE

SYNTAX:

Generalized non-resettable counter

DESCRIPTION:

A read-only count of Unavailable Seconds (UAS) on the GBS during the 15-minute performance history interval, indexed by the `aGroupPerf15MinIntervalNumber`.
See 4.2.3 for the definition of UAS.

5.5.1.62 *aGroupPerf1DayIntervalNumber*

ATTRIBUTE

SYNTAX:

INTEGER (1..7)

DESCRIPTION:

A read-only number of the 1-day performance history interval. Interval 1 is the most recent previous interval; interval 7 is 7 days ago.
Intervals 2..7 are OPTIONAL

5.5.1.63 *aGroupPerf1DayIntervalValid*

ATTRIBUTE

SYNTAX:

BOOLEAN

DESCRIPTION:

A read-only attribute indicating whether or not this history bucket contains valid data. Valid bucket is reported as true (1) and invalid bucket as false (2).
If this history bucket is invalid the BTU-C MUST NOT produce notifications based upon the value of the counters in this bucket.
Note that an implementation may decide not to store invalid history buckets in its data base. In such case this object is not required as only valid history buckets are available while invalid history buckets are simply not in the data base.

5.5.1.64 *aGroupPerf1DayIntervalMoniSecs*

ATTRIBUTE

SYNTAX:

Generalized non-resettable counter

DESCRIPTION:

A read-only number of seconds during the 1-day performance interval, indexed by the `aGroupPerf1DayIntervalNumber`, over which the performance monitoring information is actually counted. This value will be the same as the interval duration except in a situation where performance monitoring data could not be collected for any reason.

5.5.1.65 *aGroupPerf1DayIntervalES*

ATTRIBUTE

SYNTAX:

Generalized non-resettable counter

DESCRIPTION:

A read-only count of Errored Seconds (ES) on the GBS during the 1-day performance history interval, indexed by the `aGroupPerf1DayIntervalNumber`. See 4.2.1 for the definition of ES.

5.5.1.66 aGroupPerf1DayIntervalSES

ATTRIBUTE

SYNTAX:

Generalized non-resettable counter

DESCRIPTION:

A read-only count of Severely Errored Seconds (SES) on the GBS during the 1-day performance history interval, indexed by the `aGroupPerf1DayIntervalNumber`. See 4.2.2 for the definition of SES.

5.5.1.67 aGroupPerf1DayIntervalUAS

ATTRIBUTE

SYNTAX:

Generalized non-resettable counter

DESCRIPTION:

A read-only count of Unavailable Seconds (UAS) on the GBS during the 1-day performance history interval, indexed by the `aGroupPerf1DayIntervalNumber`. See 4.2.3 for the definition of UAS.

5.5.2 oBondATM**5.5.2.1 alMARxLostCells**

ATTRIBUTE

SYNTAX:

Generalized non-resettable counter

DESCRIPTION:

A read-only number of lost ATM cells detected by the receiving G.998.1 based GBS.

This object maps to the *Upstream Group Rx cell loss count* parameter of G.998.1.

5.5.2.2 alMAPeerRxLostCells

ATTRIBUTE

SYNTAX:

Generalized non-resettable counter

DESCRIPTION:

A read-only number of lost ATM cells detected by the Peer receiving G.998.1 based GBS.

This object maps to the *Downstream Group Rx cell loss count* parameter of G.998.1.

5.5.2.3 *alMAMaxUpDiffDelay*

ATTRIBUTE

SYNTAX:

INTEGER

DESCRIPTION:

This read-only object identifies current maximum upstream differential delay between all operational BCEs in the bonding group, in units of 0.1ms.

5.5.2.4 *alMAMaxDownDiffDelay*

ATTRIBUTE

SYNTAX:

INTEGER

DESCRIPTION:

This read-only object identifies current maximum downstream differential delay between all operational BCEs in the bonding group, in units of 0.1ms.

5.5.2.5 *alMAUpDiffDelayTolerance*

ATTRIBUTE

SYNTAX:

INTEGER

DESCRIPTION:

A desired maximum upstream differential delay (among the member BCEs) of the G.998.1 based GBS, in ms.

This attribute is read-write for the GBS-C and irrelevant for the GBS-R ports.

This attribute maps to the *Upstream Differential Delay Tolerance* parameter of the G.998.1.

5.5.2.6 *alMADownDiffDelayTolerance*

ATTRIBUTE

SYNTAX:

INTEGER

DESCRIPTION:

A desired maximum downstream differential delay (among the member BCEs) of the G.998.1 based GBS, in ms.

This attribute is read-write for the GBS-C and irrelevant for the GBS-R ports.

This attribute maps to the *Downstream Differential Delay Tolerance* parameter of the G.998.1.

5.5.2.7 *alMADiffDelayToleranceExceededEnable*

ATTRIBUTE

SYNTAX:

BOOLEAN

DESCRIPTION:

A read-write value indicating whether *nIMAMaxUpDiffDelayToleranceExceeded* and *nIMAMaxDownDiffDelayToleranceExceeded* notifications should be generated for the

G.998.1 based GBS port. Value of true (1) indicates that the notifications are enabled. Value of false (2) indicates that the notifications are disabled.

5.5.2.8 *nIMADiffDelayToleranceExceeded*

NOTIFICATION

SYNTAX:

SEQUENCE OF { aIMADiffDelayTolerance, aIMAMaxUpDiffDelay }

DESCRIPTION:

This notification indicates that the maximum upstream differential delay has exceeded the max upstream differential delay threshold, specified by aIMADiffDelayTolerance.

This notification MAY be sent for the GBS-C ports while the port is up, on the crossing event in both directions: from normal (diff. delay is above the threshold) to low (diff. delay equals the threshold or below it) and from low to normal. This notification is not applicable to the GBS-R ports.

Generation of this notification is controlled by the aIMADiffDelayToleranceExceededEnable attribute.

5.5.2.9 *nIMADownDiffDelayToleranceExceeded*

NOTIFICATION

SYNTAX:

SEQUENCE OF { aIMADownDiffDelayTolerance, aIMAMaxDownDiffDelay }

DESCRIPTION:

This notification indicates that the maximum downstream differential delay has exceeded the max downstream differential delay threshold, specified by aIMADownDiffDelayTolerance.

This notification MAY be sent for the GBS-C ports while the port is up, on the crossing event in both directions: from normal (diff. delay is above the threshold) to low (diff. delay equals the threshold or below it) and from low to normal. This notification is not applicable to the GBS-R ports.

Generation of this notification is controlled by the aIMADiffDelayToleranceExceededEnable attribute.

5.5.3 *oBondEth*

5.5.3.1 *aEthBACPSupported*

ATTRIBUTE

SYNTAX:

BOOLEAN

DESCRIPTION:

A read-only value, indicating whether Bonding Aggregation Control Protocol (BACP - frame-based discovery, aggregation and link management protocol specified in Annex C/G.998.2 [4]) is supported by the G.998.2 based port. Value of true (1) indicates that the BACP is supported (and can be enabled or disabled via aEthAdminCP). Value of false (2) indicates that the BACP is unsupported.

5.5.3.2 *aEthAdminCP*

SYNTAX:

ENUM { cpHS, cpBACP }

DESCRIPTION:

A read-write value, indicating desired bonding control protocol for a G.998.2 based bonding group. A default value of "cpHS" instructs the bonding group to use G.hs-based discovery and aggregation exclusively, as specified in ITU-T G.998.2. A value of "cpBACP" instructs the group to use frame-based BACP exclusively, as specified in ITU-T G.998.2 Amendment 2, Annex C.

Attempts to set a bonding group to a non-supported bonding control protocol (see aEthBACPSupported) MUST be rejected.

Changing aEthAdminCP MUST be done when the link is down. Attempts to change this object MUST be rejected if the link is up or initializing.

5.5.3.3 aEthOperCP

ATTRIBUTE

SYNTAX:

ENUM { unknown, cpHS, cpBACP }

DESCRIPTION:

A read-only value indicating current bonding control protocol used by a G.998.2 based bonding group for discovery, aggregation and link management. A value of "cpHS" indicates that the bonding group is using G.hs-based discovery and aggregation. A value of "cpBACP" indicates that the group is using frame-based BACP discovery, aggregation and link management protocol. A value of "unknown" is returned when the link is down.

5.5.3.4 aEthTcAdminType

ATTRIBUTE

SYNTAX:

ENUM { tc6465, tcHDLC }

DESCRIPTION:

A read-write value, indicating desired type of PTM-TC of an Ethernet bonding group. A value of "tc6465" instructs the bonding group to use 64/65-octet encapsulation, as specified in IEEE 802.3 Clause 61.3.3. A value of "tcHDLC" instructs the group to use HDLC encapsulation, as specified in Annex B/ITU-T G.998.2 [2].

Attempts to set a bonding group to a non-supported PTM-TC encapsulation type (see aEthTcTypesSupported) MUST be rejected.

Changing aEthTcAdminType is a traffic disruptive operation and as such MUST be done when the link is Down. Attempts to change this object MUST be rejected if the link is up or initializing.

5.5.3.5 aEthTcOperType

ATTRIBUTE

SYNTAX:

ENUM { tc6465, tcHDLC }

DESCRIPTION:

A read-only value indicating current PTM-TC encapsulation type of a bonding group. A value of "tc6465" indicates that the bonding group is using 64/65-octet

PTM-TC encapsulation. A value of "tcHDLC" indicates that the group is using HDLC encapsulation.

5.5.3.6 aEthTcTypesSupported

ATTRIBUTE

SYNTAX:

BITS { tc6465, tcHDLC }

DESCRIPTION:

A read-only bitmap of possible supported PTM-TC encapsulations. A bit position "tc6465" indicates, when set, that the bonding group can support 802.3 Clause 61.3.3 64/65-octet encapsulation. A bit position "tcHDLC" indicates, when set, that HDLC encapsulation is supported.

5.5.3.7 aEthRxErrors

ATTRIBUTE

SYNTAX:

Generalized non-resettable counter

DESCRIPTION:

A number of errored fragments that have been received across the gamma interface and discarded.

5.5.3.8 aEthRxSmallFragments

ATTRIBUTE

SYNTAX:

Generalized non-resettable counter

DESCRIPTION:

A number of fragments smaller than minFragmentSize (64 Bytes), that have been received across the gamma interface and discarded.

5.5.3.9 aEthRxLargeFragments

ATTRIBUTE

SYNTAX:

Generalized non-resettable counter

DESCRIPTION:

A number of fragments larger than maxFragmentSize (512 Bytes), that have been received across the gamma interface and discarded.

5.5.3.10 aEthRxBadFragments

ATTRIBUTE

SYNTAX:

Generalized non-resettable counter

DESCRIPTION:

A number of fragments which do not fit into the sequence expected by the frame assembly function, that have been received across the gamma interface and discarded.

5.5.3.11 aEthRxLostFragments

ATTRIBUTE

SYNTAX:

Generalized non-resettable counter

DESCRIPTION:

A number of gaps in the sequence of fragments that have been received across the gamma interface (the frame buffer is flushed to the next valid frame start, when fragment/fragments expected by the frame assembly function is/are not received).

5.5.3.12 aEthRxLostStarts

ATTRIBUTE

SYNTAX:

Generalized non-resettable counter

DESCRIPTION:

A number of missing StartOfPacket indicators expected by the frame assembly function.

5.5.3.13 aEthRxLostEnds

ATTRIBUTE

SYNTAX:

Generalized non-resettable counter

DESCRIPTION:

A number of missing EndOfPacket indicators expected by the frame assembly function.

5.5.3.14 aEthRxOverflows

ATTRIBUTE

SYNTAX:

Generalized non-resettable counter

DESCRIPTION:

A numbers of fragments, received across the gamma interface and discarded, which would have caused the frame assembly buffer to overflow

5.5.4 oBondTDIM**5.5.4.1 aCRC4Errors**

ATTRIBUTE

SYNTAX:

Generalized non-resettable counter

DESCRIPTION:

The total number of CRC-4 errors (frame header error) on all pairs in the G.998.3 port. Simultaneous errors on M lines SHOULD be counted M times.

This object maps to G.998.3 attribute *aCRC4Errors*.

5.5.4.2 aCRC6Errors

ATTRIBUTE

SYNTAX:

Generalized non-resettable counter

DESCRIPTION:

The total number of CRC-6 errors (super-frame error) on all pairs in the G.998.3 port. Simultaneous errors on M lines SHOULD be counted 1 time.

This object maps to G.998.3 attribute *aCRC6Errors*.

5.5.4.3 aCRC8Errors

ATTRIBUTE

SYNTAX:

Generalized non-resettable counter

DESCRIPTION:

The total number of CRC-8 errors (event/message error) on all pairs in the G.998.3 port. Simultaneous errors on M lines SHOULD be counted 1 time.

This object maps to G.998.3 attribute *aCRC8Errors*

5.5.4.4 aFECSupported

ATTRIBUTE

SYNTAX:

BOOLEAN

DESCRIPTION:

A read-only value indicating OPTIONAL FEC and Interleaver Capability of the G.998.3 based port.

This object has a value of true (1) when the port supports the FEC and Interleaver function.

A value of false (2) is returned when the port does not support the FEC and Interleaver function.

This object maps to the G.998.3 attribute *aFECSupported*.

5.5.4.5 aFECAdminState

ATTRIBUTE

SYNTAX:

BOOLEAN

DESCRIPTION:

A read-write value, indicating a desired state of the OPTIONAL Forward Error Correction (FEC) function for the G.998.3 port.

A value of 'false' indicates that the FEC function MUST be disabled. A value of 'true' indicates that the FEC function MUST be enabled, if supported by the G.998.3 port, as indicated by the aFECSupported object.

For the GBS-R ports, the value of this object cannot be changed directly. This value may be changed as a result of writing operation on the aFECSupported object of a remote GBS-C.

Modifications of this object MUST be performed when the link is Down.

Attempts to change this object MUST be rejected (in case of SNMP with the error inconsistentValue), if the link is up or initializing or if it is a GBS-R.

This object maps to G.998.3 attribute *aFECAdminState*.

5.5.4.6 aFECOperState

ATTRIBUTE

SYNTAX:

BOOLEAN

DESCRIPTION:

A read-only value, indicating current operational state of the OPTIONAL Forward Error Correction (FEC) function for the G.998.3 port.

A value of 'false' indicates that the FEC function is disabled. A value of 'true' indicates that the FEC function is enabled (and supported).

5.5.4.7 aFECWordSize

ATTRIBUTE

SYNTAX:

INTEGER(0|20..255)

DESCRIPTION:

A FEC code word size in octets for the G.998.3 ports supporting FEC function.

This object is read-write for the GBS-C ports and read-only for the GBS-R.

A value of zero MUST be returned if the FEC is disabled (via aFECAdminState) or not supported.

Changing of the FEC code word size MUST be performed when the FEC enabled link is Down. Attempts to change this object MUST be rejected (In case of SNMP with the error inconsistentValue), if the link is up or initializing or the FEC function is disabled/not supported.

This object maps to G.998.3 attribute *aFECWordSize*.

5.5.4.8 aFECRedundancySize

ATTRIBUTE

SYNTAX:

INTEGER(0|2|4|8|16|20)

DESCRIPTION:

A FEC redundancy word size in octets for the G.998.3 ports supporting FEC function.

This object is read-write for the GBS-C ports and read-only for the GBS-R.

A value of zero MUST be returned if the FEC is disabled (via aFECAdminState) or not supported.

Changing of the FEC redundancy word size MUST be performed when the FEC enabled link is Down. Attempts to change this object MUST be rejected, if the link is up or initializing or the FEC function is disabled/not supported.

This object maps to G.998.3 attribute *aFECRedundancySize*.

5.5.4.9 aFECInterleaverType

ATTRIBUTE

SYNTAX:

ENUM { none, block, convolution}

DESCRIPTION:

An Interleaver type for the G.998.3 ports supporting FEC function.

This object is read-write for the GBS-C ports and read-only for the GBS-R.

A value of 'none' MUST be returned if the FEC is disabled (via *aFECAdminState*) or not supported.

Changing of the Interleaver type MUST be performed when the FEC enabled link is Down. Attempts to change this object MUST be rejected, if the link is up or initializing or the FEC function is disabled/not supported.

This object maps to G.998.3 attribute *aFECInterleaverType*.

5.5.4.10 aFECInterleaverDepth

ATTRIBUTE

SYNTAX:

INTEGER(0|1|2|3|4|6|8|12|16|24|32|48|96)

DESCRIPTION:

An Interleaver Depth for the G.998.3 ports supporting FEC function.

This object is read-write for the GBS-C ports and read-only for the GBS-R.

A value of zero MUST be returned if the FEC is disabled (via *aFECAdminState*) or not supported.

Changing of the Interleaver Depth MUST be performed when the FEC enabled link is Down. Attempts to change this object MUST be rejected, if the link is up or initializing or the FEC function is disabled/not supported.

This object maps to G.998.3 attribute *aFECInterleaverDepth*

5.5.4.11 aFECMaxWordSize

ATTRIBUTE

SYNTAX:

INTEGER(0|20..255)

DESCRIPTION:

A read-only value indicating Maximum supported FEC code word size in octets for the G.998.3 ports with FEC function. A value of zero MUST be returned if the FEC is not supported.

This object partially maps to G.998.3 attribute *aFECMaxWordSize*.

5.5.4.12 aFECMaxRedundancySize

ATTRIBUTE

SYNTAX:

INTEGER(0|2|4|8|16|20)

DESCRIPTION:

A read-only value indicating a maximum supported FEC redundancy word size in octets for the G.998.3 ports with FEC function.

A value of zero MUST be returned if the FEC is not supported.

This object partially maps to G.998.3 attribute *aFECRedundancySize*

5.5.4.13 aFECInterleaverTypesSupported

ATTRIBUTE

SYNTAX:

ENUM { none, block, convolution, blockConvolution }

DESCRIPTION:

A read-only list of values indicating Supported Interleaver types for the G.998.3 ports with FEC function.

This object partially maps to G.998.3 attribute *aFECInterleaverType*

5.5.4.14 aFECMaxInterleaverDepth

ATTRIBUTE

SYNTAX:

INTEGER(0|1|2|3|4|6|8|12|16|24|32|48|96)

DESCRIPTION:

A read-only value indicating a Maximum Interleaver Depth for the G.998.3 ports with FEC function.

A value of zero MUST be returned if the Interleaver is not supported.

This object partially maps to G.998.3 attribute *aFECInterleaverDepth*.

5.5.5 oTDIMService

5.5.5.1 aServiceID

ATTRIBUTE

SYNTAX:

INTEGER

DESCRIPTION:

G.998.3 Service index - a unique read-only index associated with a particular service entry, indicating relative placement of the service inside the G.998.3 based frame.

There can be up to 60 services defined over TDIM bonded facility. Services with lower indices have higher priority in case of bandwidth degradation.

This objects maps to G.998.3 attribute *aServiceID*.

5.5.5.2 aServiceIndex

ATTRIBUTE

SYNTAX:

INTEGER

DESCRIPTION:

A unique index representing the interface index of a service to be transmitted over the G.998.3 based service instance

5.5.5.3 aServiceType

ATTRIBUTE

SYNTAX:

ENUM { ds1, e1, nxds0, nxe0, ds3, e3, clock, Ethernet, atm, gfpNoFCS, gfp }

DESCRIPTION:

A value representing G.998.3 Service Type.

Possible values are:

ds1	- Clear Channel DS1 (synchronous)
e1	- Clear Channel E1 (synchronous)
nxds0	- Fractional DS1 (synchronous)
nxe0	- Fractional E1 (synchronous)
ds3	- DS3 (synchronous)
e3	- E3 (synchronous)
clock	- Clock transfer (synchronous)
ethernet	- Ethernet (asynchronous)
atm	- ATM (asynchronous)
gfpNoFCS	- GFP encapsulated without FCS (asynchronous)
gfp	- GFP encapsulated with FCS (asynchronous)

For the GBS-R ports, the value of this object cannot be changed directly. This value may be changed as a result of writing operation on the aServiceType object of a remote GBS-C.

Modifications of this object MUST be performed when the link is Down.

Attempts to change this object MUST be rejected (in case of SNMP with the error inconsistentValue), if the link is up or initializing or if it is a GBS-R.

This object maps to G.998.3 attribute *aServiceType*

5.5.5.4 aServiceSize

ATTRIBUTE

SYNTAX:

INTEGER

DESCRIPTION:

Service size in octets per bonding sub-block for a specific service identified by gServiceID.

For TDM (synchronous) services with variable size e.g. fractional DS1/E1 - this object represents the number of DS0/E0 channels.

For asynchronous services (Ethernet, ATM, GFPnoFCS or GFP) - this object represents maximum number of octets.

A GET operation returns current value. A SET operation, allowed on GBS-C only when the link is Down, changes the service size to the indicated value. If the link

is not down or the service type is fixed rate TDM service (aServiceType is NxDS0, NxE0, DS1, E1, DS3, E3 or Clock), the operation MUST be rejected (in case of SNMP with the error inconsistentValue).

This object MUST be maintained in a persistent manner.

This object maps to G.998.3 attribute *aServiceSize*

5.5.5.5 aServiceOperState

ATTRIBUTE

SYNTAX:

ENUM { up, down }

DESCRIPTION:

G.998.3 Service Operation State. The value of "up" indicates that the service is up passing traffic. The value of "down" indicates that the Service is down, due to a variety of reasons, e.g. G.998.3 port is down, current link bandwidth is too low to support a particular service, etc.

5.5.5.6 aServiceUpDownEnable

ATTRIBUTE

SYNTAX:

BOOLEAN

DESCRIPTION:

A read-write value indicating whether nServiceUp and nServiceDown notifications should be generated for the particular service in the G.998.3 based port. Value of true (1) indicates that the notifications are enabled. Value of false (2) indicates that the notifications are disabled.

5.5.5.7 nServiceUp

NOTIFICATION

SYNTAX:

SEQUENCE OF { aServiceIfIndex, aServiceOperState }

DESCRIPTION:

This notification indicates that the G.998.3 based Service has transitioned to an "up" state, as indicated by aServiceOperState (capable of passing traffic). Generation of this notification is controlled by the aServiceUpDownEnable attribute 5.5.5.6.

5.5.5.8 nServiceDown

NOTIFICATION

SYNTAX:

SEQUENCE OF { aServiceIfIndex, aServiceOperState }

DESCRIPTION:

This notification indicates that the G.998.3 based Service has transitioned to a "down" state, as indicated by aServiceOperState (incapable of passing traffic). Generation of this notification is controlled by the aServiceUpDownEnable attribute 5.5.5.6.

5.5.6 oLine

5.5.6.1 aLineID

ATTRIBUTE

SYNTAX:

INTEGER

DESCRIPTION:

A read-only value to uniquely identify a particular xDSL line interface (copper pair).

This object maps to aPairPhysicalID attribute of G.998.3.

When SNMP is used to manage the BTU, the aLineID is represented by the IF-MIB ifIndex object.

5.5.6.2 aLineType

ATTRIBUTE

SYNTAX:

ENUM { shdsl, adsl, adsl2plus, vdsl, vdsl2 }

DESCRIPTION:

A read-only value to indicating the type of xDSL technology supported by a particular xDSL line interface.

When SNMP is used to manage the BTU, the aLineType is represented by the IF-MIB ifType object.

5.5.6.3 aLineOperState

ATTRIBUTE

SYNTAX:

ENUM { down, init, up }

DESCRIPTION:

A read-only value indicating current operational state of an xDSL line interface. A value of "down" indicates that the line interface is operationally down. A value of "init" indicates that the line is initializing. A value of "up" indicates that the line interface is operationally up and is able to pass traffic.

When SNMP is used to manage the BTU, the aLineOperState is represented by the IF-MIB ifOperStatus object.

5.5.6.4 aLineStatus

ATTRIBUTE

SYNTAX:

BITS { noDefect, lineAtnDefect, lineFault, configInitFault, protocolInitFault, noPeer }

DESCRIPTION:

A read-only value indicating current fault status of an xDSL line. This is a bitmap of possible faults. The bit positions are:

noDefect	No defects on the line are detected
lineAtnDefect	Line Attenuation exceeds the threshold
lineFault	Link Fault has been detected
configInitFault	Configuration initialization failure, due to inability of the BCE link to support the configuration profile,

	requested during initialization.
protocolInitFailure	Protocol initialization failure, due to an incompatible protocol used by the peer during init (e.g. if a peer BCE is a regular xDSL modem instead of a G.998.x BCE).
noPeer	No activation sequence from the peer is detected during init.

This object is defined here only for the purpose of completeness. For each xDSL technology a relevant managed object indicating the current fault status is defined in the corresponding management specification, for example, when SNMP is used to manage the BTU, hdsl2ShdslEndpointCurrStatus object defined in HDLSL2-SHDSL-LINE-MIB or vdslPhysCurrStatus object defined in VDSL-LINE-MIB provide the required functionality for the G.SHDSL or VDSL lines respectively

5.5.6.5 *aLineEnd*

ATTRIBUTE

SYNTAX:

ENUM {subscriber, office, unknown}

DESCRIPTION:

A read-only value to uniquely identify a sub-type of the xDSL line interface. A value of "subscriber" indicates that the line operates as -R (Remote Terminal side). A value of "office" indicates that the port operates as -C (Central Office side). A value of "unknown" indicates that the line's sub-type cannot be determined.

This object is defined here only for the purpose of completeness. For each xDSL technology a relevant managed object indicating the "side" of the line interface is defined in the corresponding management specification. For example when SNMP is used to manage the BTU, hdsl2ShdslEndpointSide object defined in HDLSL2-SHDSL-LINE-MIB or vdslPhysSide object defined in VDSL-LINE-MIB provide the required functionality for the G.SHDSL or VDSL lines respectively.

5.5.6.6 *aLineAdminState*

ATTRIBUTE

SYNTAX:

ENUM { down, up }

DESCRIPTION:

A read-write value, indicating current desired state of an xDSL line interface. A value of "down" instructs the line interface to be operationally down. A value of "up" instructs the line to be operationally up and is able to pass traffic. The aLineOperState attribute indicates current operational state of an xDSL line interface.

When SNMP is used to manage the BTU, the aLineAdminState is represented by the IF-MIB ifAdminStatus object.

5.5.6.7 *aLineRemoteDiscoveryCode*

ATTRIBUTE

SYNTAX:

OCTET STRING (6)

DESCRIPTION:

A 6-octet long Remote Discovery Code of the peer GBS-R connected via specific BCE-C, used by the OPTIONAL G.hs-based Discovery.

Reading this object results in a Discovery Get operation.

Setting this object to all zeroes results in a Discovery Clear_if_Same operation (the value of aGroupDiscoveryCode at the peer GBS-R MUST be the same as aGroupDiscoveryCode of the local GBS-C associated with the BCE for the operation to succeed).

Writing a non-zero value to this object results in a Discovery Set_if_Clear operation.

This object is irrelevant in BCE-R port subtypes (CPE side): in this case a zero length octet string MUST be returned on an attempt to read this object, writing to this object MUST be rejected.

Discovery MUST be performed when the link is Down.

Attempts to change this object MUST be rejected (in case of SNMP with the error inconsistentValue), if the link is up or initializing.

5.5.6.8 aLineUpDownEnable

ATTRIBUTE

SYNTAX:

BOOLEAN

DESCRIPTION:

A read-write value indicating whether nLineUp and nLineDown notifications should be generated for the xDSL line participating in a bonded link. Value of true (1) indicates that the notifications are enabled. Value of false (2) indicates that the notifications are disabled.

5.5.6.9 nLineUp

NOTIFICATION

SYNTAX:

SEQUENCE OF { aLineAdminState, aLineStatus }

DESCRIPTION:

This notification indicates that the xDSL line has transitioned to an "up" status, as indicated by aLineStatus.

When SNMP is used to manage the BTU, the nLineUp is represented by the IF-MIB linkUp notification.

Generation of this notification is controlled by the aLineUpDownEnable attribute.

5.5.6.10 nLineDown

NOTIFICATION

SYNTAX:

SEQUENCE OF { aLineAdminState, aLineStatus }

DESCRIPTION:

This notification indicates that the xDSL line has transitioned to a "down" status, as indicated by aLineStatus.

When SNMP is used to manage the BTU, the nLineDown is represented by the IF-MIB linkDown notification.

Generation of this notification is controlled by the aLineUpDownEnable attribute.

5.5.7 oChannel

5.5.7.1 aChannelID

ATTRIBUTE

SYNTAX:

INTEGER

DESCRIPTION:

A read-only value to uniquely identify a Bonding Channel Entity (BCE).

When SNMP is used to manage the BTU, the aChannelID is represented by the IF-MIB ifIndex object.

5.5.7.2 aChannelGroupID

ATTRIBUTE

SYNTAX:

INTEGER(0..31)

DESCRIPTION:

A read-only value identifying a particular bonding channel within a bonding group, i.e. logical number of a BCE in a GBS.

This object maps to the *PME ID variable* of G.998.2 Amendment 2 or to the aPairID attribute of G.998.3 or to the *Tx link number* of G.998.1.

5.5.7.3 aChannelEligibleGroupID

ATTRIBUTE

SYNTAX:

OCTET STRING (6)

DESCRIPTION:

A universally unique 6-octet identifier, used by OPTIONAL BACP to determine group eligibility. When two BCEs have the same aChannelEligibleGroupID on a system, they are eligible to be aggregated on that system. Typically, all BCEs on a BTU-R device would be assigned the same aChannelEligibleGroupID, to assert that all of the BCEs should be in the same bonded group. BCEs with different aChannelEligibleGroupID values **MUST NOT** be connected to the same GBS. BCEs with the same aChannelEligibleGroupID **MAY** be connected to different GBS ports.

This object **MUST** be instantiated during BACP initialization, when every BCE belongs to its own GBS. This object **MUST NOT** be modified while the BCE is aggregated with other BCEs.

An attempt to modify the value of this object **MUST** be rejected if the BCE in question is not eligible to be bonded with other BCEs having the same value (e.g. the bonding is limited to a single Line Card and BCEs are located on the different Line Cards, or BCEs are the channels of the same line).

This object maps to the *Group ID (GID) variable* in G.998.2 Amendment 2.

5.5.7.4 aChannelEligibleStreamID

ATTRIBUTE

SYNTAX:

INTEGER

DESCRIPTION:

A read-write value uniquely identifying a Channel within an eligible group, i.e. BCEs with the same aChannelEligibleGroupID, used by OPTIONAL BACP. This object MUST be instantiated during BACP initialization, when every BCE belongs to its own GBS. This object MUST NOT be modified while the BCE is aggregated with other BCEs.

This object maps to the *Stream ID variable* in G.998.2 Amendment 2.

5.5.7.5 aChannelType

ATTRIBUTE

SYNTAX:

ENUM { shdsl, adsl, adsl2plus, vdsl, vdsl2 }

DESCRIPTION:

A read-only value to indicating the type of xDSL technology supported by a particular BCE.
When SNMP is used to manage the BTU, the aChannelType is represented by the IF-MIB ifType object.

5.5.7.6 aChannelOperState

ATTRIBUTE

SYNTAX:

ENUM { down, init, up }

DESCRIPTION:

A read-only value indicating current operational state of a bonding group. A value of "down" indicates that the bonding group is operationally down. A value of "init" indicates that the group is initializing. A value of "up" indicates that the group is operationally up and is able to pass traffic.

5.5.7.7 aChannelStatus

ATTRIBUTE

SYNTAX:

BITS { noDefect, lossOfDslFraming, lossOfTcFraming, lossOfQuality }

DESCRIPTION:

A read-only value indicating current fault status of an xDSL channel. This is a bitmap of possible faults. The bit positions are:

noDefect	no defects on the line are detected
lossOfDslFraming	Loss of Framing for vdsl/adsl or Loss of Sync word for SHDSL
lossOfTcFraming	Loss of the framing/encapsulation (e.g. loss of 64/65-octet or HDLC framing or cell delineation)
lossOfQuality	the bit-error-rate exceeds 10^{-7}

This object is intended to supplement ifOperStatus in IF-MIB.

This object partly maps to an xDSL-specific managed object indicating the current fault status for a channel, defined in the corresponding management specification. For example, when SNMP is used to manage the BTU, aChannelStatus would partly map to hdsl2ShdslEndpointCurrStatus object defined in HDSL2-SHDSL-LINE-MIB or vdslPhysCurrStatus object defined in VDSL-LINE-MIB for the G.SHDSL or VDSL lines respectively.

5.5.7.8 aChannelPtmTcRxCodingViolations

ATTRIBUTE

SYNTAX:

Generalized non-resettable counter

DESCRIPTION:

A number of PTM-TC encapsulation errors. This counter is incremented for each encapsulation error detected by the PTM-TC receive function.

5.5.7.9 aChannelPtmTcRxCrcErrors

ATTRIBUTE

SYNTAX:

Generalized non-resettable counter

DESCRIPTION:

A number of PTM-TC CRC errors. This counter is incremented for each CRC error detected by the PTM-TC receive function.

End of Broadband Forum Technical Report TR-159